

Knowledge Tracing with Sequential Key-Value Memory Networks

Ghodai Abdelrahman and Qing Wang



Australian National University
Research School of Computer Science
Canberra, Australia

{ghodai.abdelrahman, qing.wang}@anu.edu.au

June 17, 2021

Knowledge Tracing – Introduction

- **Question:** Can machines trace human knowledge like humans?



(Image source: The New York Academy of Sciences)

Knowledge Tracing – Introduction

- Human educators can intelligently track the knowledge of a student.

Assistment ID: 44667 [Comment on this question](#)

Use the properties of equality to solve the equation for x:

$$3x - 50 = 100$$

← Asked for a hint

What is the value for x?

If you want to solve for x, first you must undo the subtraction of fifty on the left side of the equation. The opposite of subtraction is addition. You need to add fifty to BOTH sides of the equation.

[Comment on this hint](#)

Type your answer below (mathematical expression):

8

← Made a wrong attempt

✖ Sorry, try again: "8" is not correct



Knowledge Tracing – Introduction

- Knowledge tracing aims to build a model that can trace the knowledge of students as they interact with coursework items.

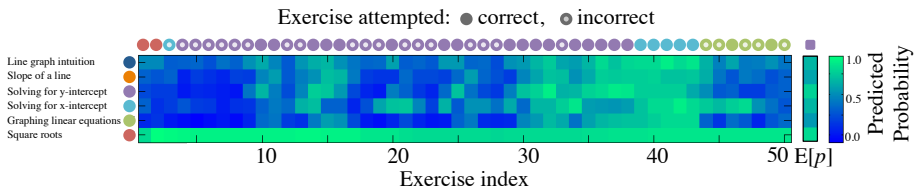

(Image source: Deep Knowledge Tracing, NIPS 2015)

- This can help enable personalised learning experiences for students.

Related Work - Overview

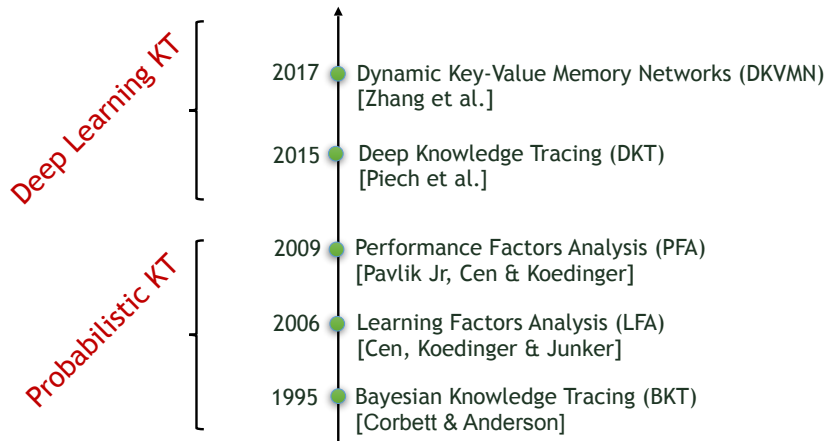

Related Work - Bayesian Knowledge Tracing

- Built upon Hidden Markov Model (HMM)
- Represent a knowledge state as a set of binary latent variables, each for student understanding of a concept (i.e., *known* and *unknown*):
 - How can we capture the relationship between different concepts?

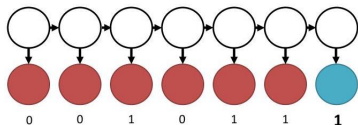

Related Work - Deep Knowledge Tracing

- Built upon Recurrent Neural Network (RNN)
- Summarise a student's knowledge state of all concepts in one hidden state, thus difficult to trace:
 - How much a student has mastered certain concepts?

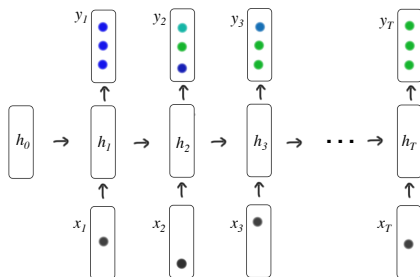

Related Work - Dynamic Key-Value Memory Networks

- Built upon Memory-Augmented Neural Network (MANN)
- Acquire knowledge growth through the most recent exercise and fail to capture long-term dependencies
- Ignore the latest knowledge state during the memory write process

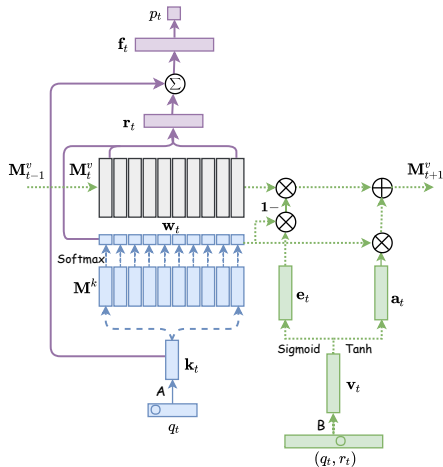

- **Research question**

Can we build a knowledge tracing model that can alleviate the limitations of the previous work?

- **Problem definition**

Given a student's exercise history $X = \langle (q_1, y_1), \dots, (q_{t-1}, y_{t-1}) \rangle$, we want to predict the probability of correctly answering the next question q_t by the student:

$$p_t = (y_t = 1 | q_t, X)$$

• Assumptions

- Each question associates with one or more **latent concepts**.
- The **concept state** of each latent concept is a random variable describing the mastery level of the student on this latent concept.
- At each time step t , the **knowledge state** of a student is modelled as a set of all concept states of the student.

• Key ingredients

- 1 A key-value memory $\langle \mathbf{M}^k, \mathbf{M}_t^v \rangle$
- 2 Hop-LSTM
- 3 Effective mechanisms for attention, read and write

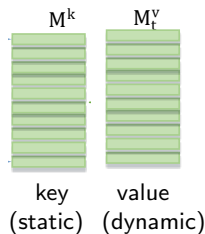

Sequential Key-Value Memory Networks (SKVMN)

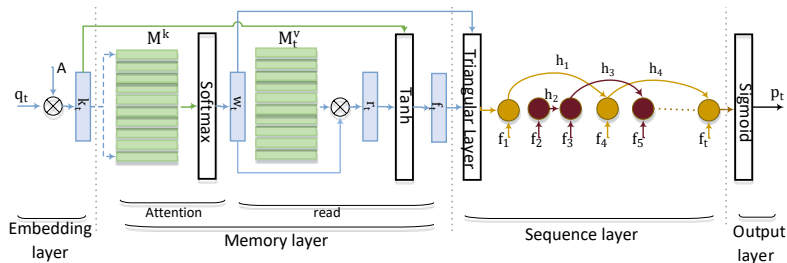

- Four layers in this model:
 - 1 **Embedding** layer maps a question into a continuous vector.
 - 2 **Memory** layer involves two processes: attention and read.
 - 3 **Sequence** layer consists of recurrently connected LSTM cells.
 - 4 **Output** layer yields probability of correctly answering a question.

Sequential Key-Value Memory Networks (SKVMN)

• Attention:

- Occur each time when a question q_t is taken.
- Provide an addressing mechanism for the input question to allocate the relevant information from the key-value memory.
- Obtain an attention vector \mathbf{w}_t by applying Softmax to the inner product between \mathbf{k}_t and each key slot $\mathbf{M}^k(i)$ in the key matrix \mathbf{M}^k :

$$\mathbf{w}_t(i) = \text{Softmax}(\mathbf{k}_t^T \mathbf{M}^k(i)).$$

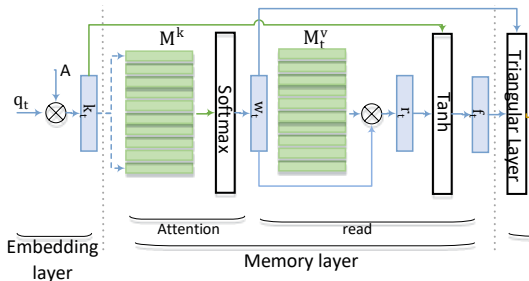

Sequential Key-Value Memory Networks (SKVMN)

• Read:

- Occur each time when a question q_t is taken.
- Use the attention vector w_t to retrieve the concept states of the student w.r.t. the question q_t from the value matrix M_t^v .
- Yield the summary vector f_t , i.e., how well the student has mastered latent concepts relevant to the question before attempting it.

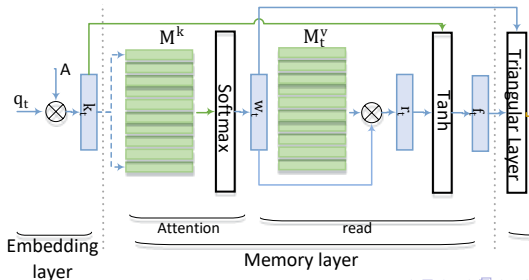

Sequential Key-Value Memory Networks (SKVMN)

- **Write:**

- Occur each time after the student has attempted a question.
- Update the concept states of the student using the knowledge growth \mathbf{v}_t gained through attempting the question.
- Lead to the transition of the value matrix from \mathbf{M}_t^v to \mathbf{M}_{t+1}^v .

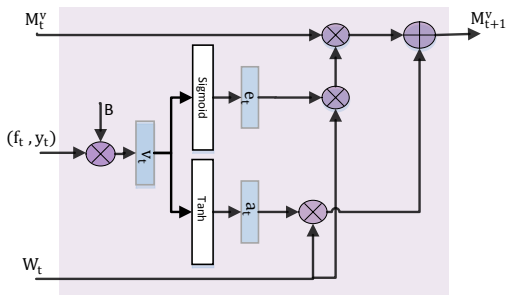

Sequential Key-Value Memory Networks (SKVMN)

• Hop-LSTM:

- An exercise history may contain a long sequence of exercises.
- By hopping across irrelevant exercises, recurrent models can be applied on a shorter and more relevant sequence.
- Sequential dependencies among exercises are identified via the attention vectors of their questions.

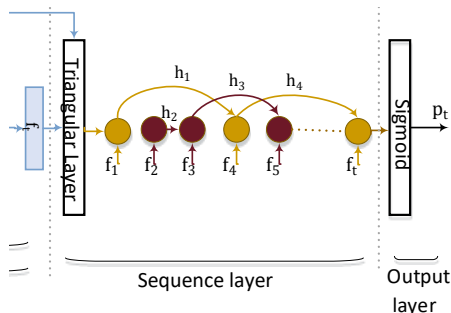

- In our experiments, we aim to answer the following questions:

RQ1: What is the optimal size for a key-value memory of SKVMN?

RQ2: How does SKVMN perform on predicting a student's answers of questions, given an exercise history?

RQ3: How does SKVMN perform on discovering the correlation between latent concepts and questions?

RQ4: How does SKVMN perform on tracing the dynamics of a student's knowledge state?

- Five datasets:

Dataset	#Questions	#Students	#Exercises	#Exercises per student
Synthetic-5	50	4,000	200,000	50
ASSISTments2009	110	4,151	325,637	78
ASSISTments2015	100	19,840	683,801	34
Statics2011	1,223	333	189,297	568
JunyiAcademy	722	199,549	25,628,935	128

- Three baselines:

- Bayesian knowledge tracing (BKT) [UMUAI1994]
- Deep knowledge tracing (DKT) [NIPS2015]
- Dynamic key-value memory networks (DKVMN) [WWW2017]

[RQ1:]What is the optimal size for a key-value memory of SKVMN?

Dataset	d	N	SKVMN		DKVMN	
			AUC (%)	m	AUC (%)	m
Synthetic-5	10	50	83.11	15K	82.00	12k
	50	50	83.67	30k	82.66	25k
	100	50	84.00	57k	82.73	50k
	200	50	83.73	140k	82.71	130k
ASSISTments2009	10	10	83.63	7.8k	81.47	7k
	50	20	82.87	35k	81.57	31k
	100	10	82.72	71k	81.42	68k
	200	20	82.63	181k	81.37	177k
ASSISTments2015	10	20	74.84	16k	72.68	14k
	50	10	74.50	31k	72.66	29k
	100	50	74.24	66k	72.64	63k
	200	50	74.20	163k	72.53	153k
Statics2011	10	10	84.50	92.8k	82.72	92k
	50	10	84.85	199k	82.84	197k
	100	10	84.70	342k	82.71	338k
	200	10	84.76	653k	82.70	649k
JunyiAcademy	10	20	82.50	16k	79.63	14k
	50	10	82.41	31k	79.48	29k
	100	50	82.67	66k	79.54	63k
	200	50	82.32	163k	80.27	153k

[RQ2:] How does SKVMN perform on predicting a student's answers of questions, given an exercise history?

Dataset	BKT	DKT	DKVMN	SKVMN
Synthetic-5	62.0 \pm 0.02	80.3 \pm 0.1	82.7 \pm 0.1	84.0 \pm 0.04
ASSISTments2009	63.1 \pm 0.01	80.5 \pm 0.2	81.6 \pm 0.1	83.6 \pm 0.06
ASSISTments2015	64.2 \pm 0.03	72.5 \pm 0.1	72.7 \pm 0.1	74.8 \pm 0.07
Statics2011	73.0 \pm 0.01	80.2 \pm 0.2	82.8 \pm 0.1	84.9 \pm 0.06
JunyiAcademy	65.0 \pm 0.02	79.2 \pm 0.1	80.3 \pm 0.4	82.7 \pm 0.01

- Key observations:

- 1 DL models generally performed better than probabilistic models.
- 2 Memory-augmented models performed better than RNN-based models.
- 3 The use of sequential dependencies among exercises in our model enhanced the prediction accuracy.

[RQ3:] How does SKVMN perform on discovering the correlation between latent concepts and questions?

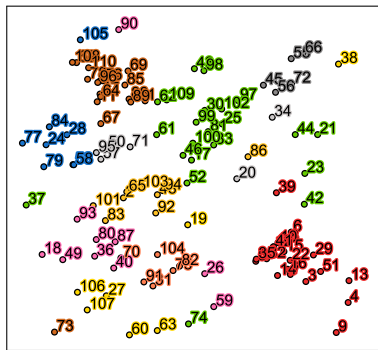

(DKVMN)

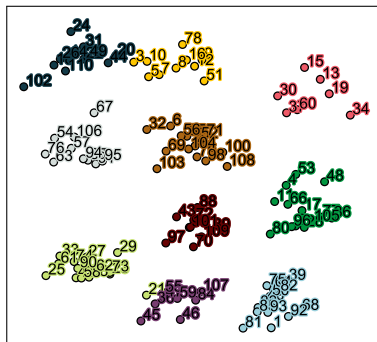

(SKVMN)

[RQ4:] How does SKVMN perform on tracing the dynamics of a student's knowledge state?

Exercise Answers ● Correct ○ Incorrect

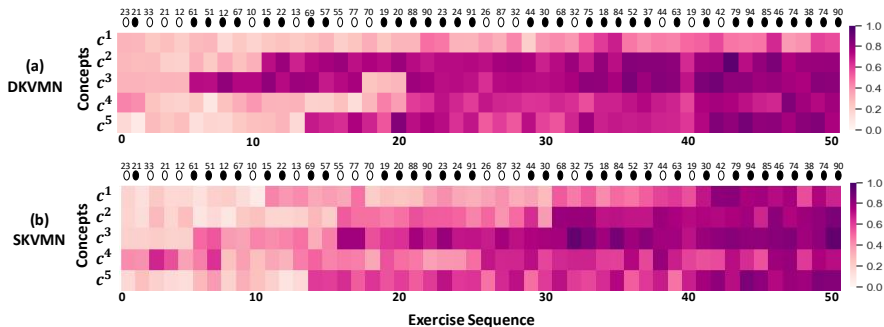

Conclusion

- We have proposed a novel knowledge tracing method called Sequential Key-Value Memory Network (SKVMN):
 - Trace knowledge states over multiple latent concepts;
 - Enhance the sequence modelling capacity;
 - Enhance memory read and writing capacity;
 - Discover the correlation between latent concepts and questions.
- Our experiments show that SKVMN outperformed the state-of-the-art methods on 5 datasets.

